Development of Smart Autonomous Lawn Mower (SALAM)

1 March 2023

A lawn mower is a machine that uses one or more rotating blades to cut grass to achieve an even height. The cutting height is usually predetermined by the machine's design, which may result in some variation in grass height.

However, operators can usually adjust the cutting height. Typically, lawn mowers are manually operated and have wheels, with the cutting blade powered by a motor that runs on fuel or batteries. Most lawn mowers use a motor with an internal combustion engine, usually a single cylinder, and require human power to move across the surface. Larger lawn mowers are equipped with an operator seat, allowing the rider to control the mower directly. A solar-powered lawn mower uses solar energy to drive an electric motor and rotate the blade to cut grass. Robotic lawn mowers are designed to operate autonomously or with less human effort and can be controlled remotely using a remote control.

When it comes to the cutting edge, there are two types: one that uses a single rotating blade and another that uses multiple blades. With the rapid advancement of technology, particularly in automation, there have been great benefits to daily life in performing routine tasks. Since COVID 19, intelligent and automated robots have been widely adopted for work that humans previously did. The use of these robots is a demand from the modern industrial world for a tool with high capabilities to assist in completing tasks and achieving optimal results. The development of robots involves not only sophisticated mechanics but also algorithmic development using computer systems to operate them.

Several types of lawn mowers are available on the market, categorised by their size and usage. Generally, they can be divided into three categories based on the size of the area to be mowed: small, medium, and large. Small-sized lawn mowers are typically without tires and are suitable for cutting grass in homes or small gardens. Medium-sized lawn mowers are powered by engines that run on electricity or gasoline and are suitable for mowing larger residential properties. For larger areas, lawn mowers mounted on small tractors are the preferred choice for users.

However, most lawn mowers available in the market still rely on petroleum-based fuels. It is well known that using such fuels contributes to air pollution. In his speech at the World Environment Day event held at Taman Tugu on 5 June 2022, the Prime Minister of Malaysia, Datuk Seri Ismail Sabri Yaakob, reaffirmed Malaysia's commitment to becoming a carbon-neutral country by as early as 2050. At the Nikkei Conference held in Japan in 2022, the Prime Minister reiterated Malaysia's commitment to enact laws related to climate change, thereby helping achieve the goal of becoming a carbon-neutral country by 2050.

Apart from that, the rising fuel prices in the market have made the use of lawn mowers a financial burden, and it is essential to find alternatives to overcome this problem. Using human power to operate a lawn mower also becomes a challenge when the entry of foreign labour is restricted due to the COVID-19 pandemic. To address this issue, a lawn mower based on an autonomous concept has

been developed, focusing on its main cutting mechanism. The development of this lawn mower incorporates the latest technology to make the work more comfortable and efficient, the equipment easier to use, reduce workers' downtime, minimise environmental pollution, and enhance the workers' safety.

Design Concept

The development of this autonomous lawn mower is a technologically advanced initiative based on the Fourth Industrial Revolution (IR4.0). Currently, most lawn mowers operate manually, requiring human labor. The use of manual lawn mowers can cause health effects, such as heat stroke due to prolonged exposure to hot temperatures. Therefore, introducing equipment based on the autonomous concept provides significant benefits in terms of efficiency, cost savings, and safety.

In developing this product, it has been divided into several modules, including the cutting module, chassis module, battery module, wheel module, safety module, and controller module (controller), as illustrated in Figure 1. The lawn mower's movement is generally autonomous and based on GPS mapping. During the cutting process, the lawn mower moves in a zig-zag pattern, which the Ardupilot system controls to ensure autonomous operation.

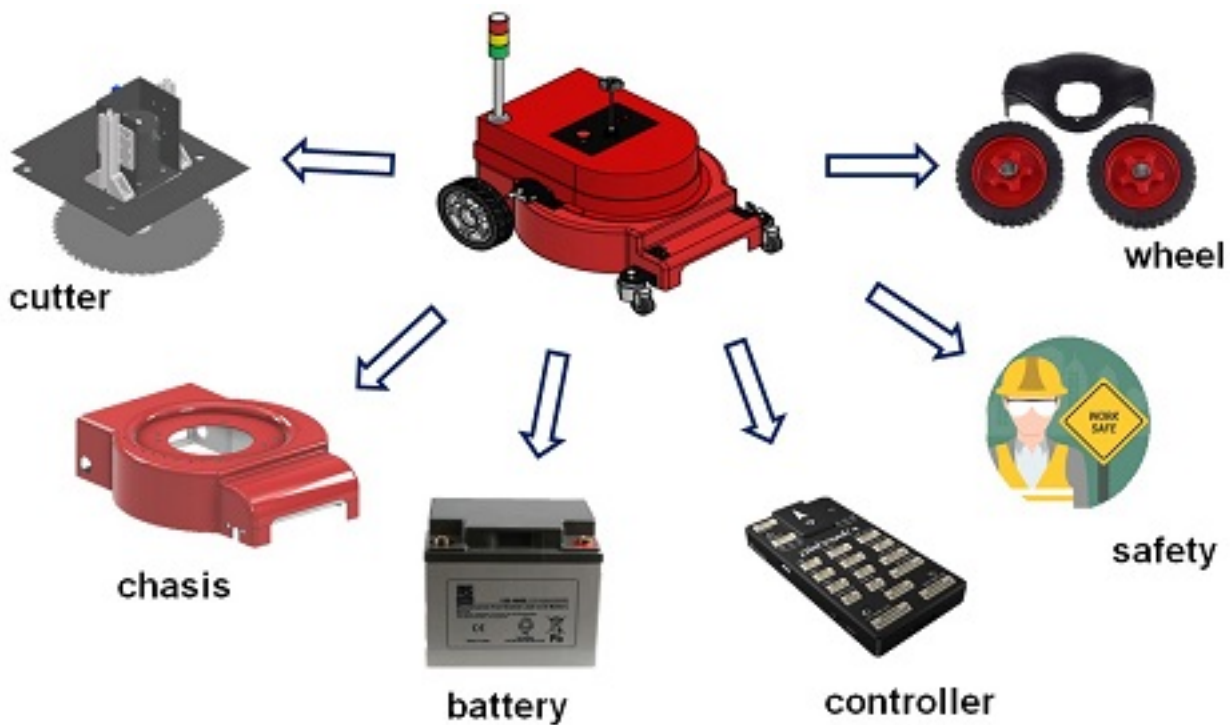

Figure 1: Project design by module

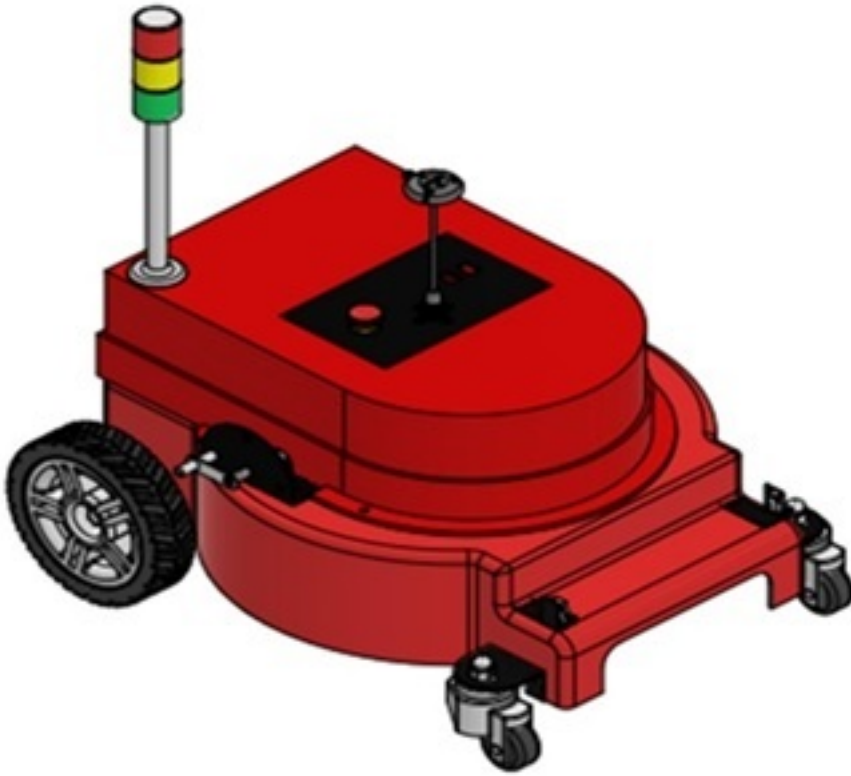

Figure 2: Lawn mower design

a. Cutter

Cutting grasses with this lawn mower uses three types of points namely blade, cutter, and nylon which is driven by a motor. Cutting levels are divided into three levels, namely low, medium, and high, to ensure that cutting quality can be achieved. The height of the low level is 30 mm from the ground level, the medium level is 40 mm, and the high level is 50 mm.

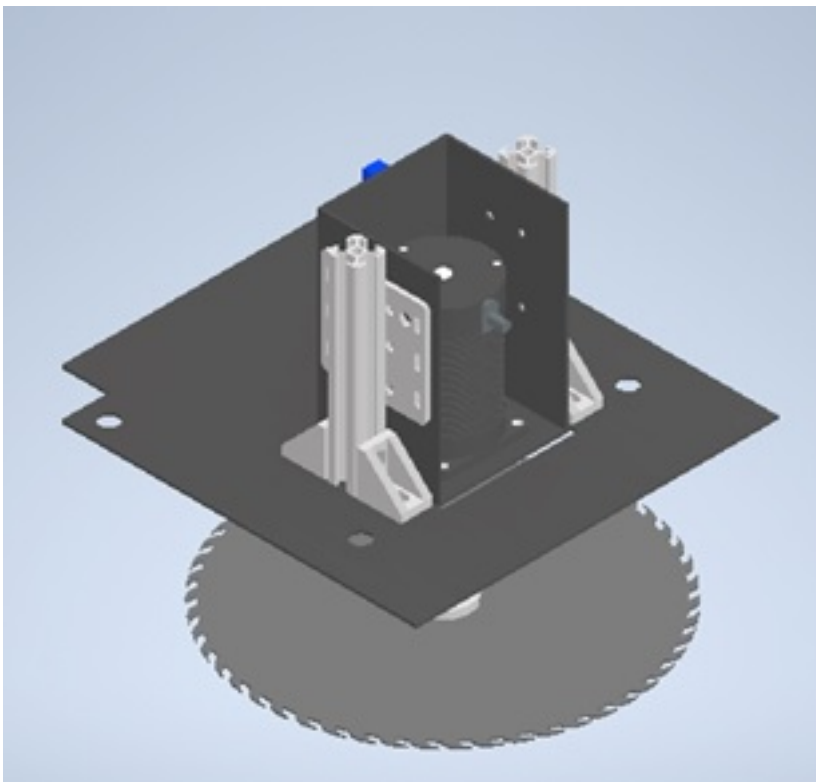

Figure 3: Cutter system

b. Chassis Frame

The main chassis of this lawn mower is composed of the main body and various components such as batteries, wheels, motors, blades, control systems, and others. The body is made of mild steel sheet metal and is divided into upper and lower parts.

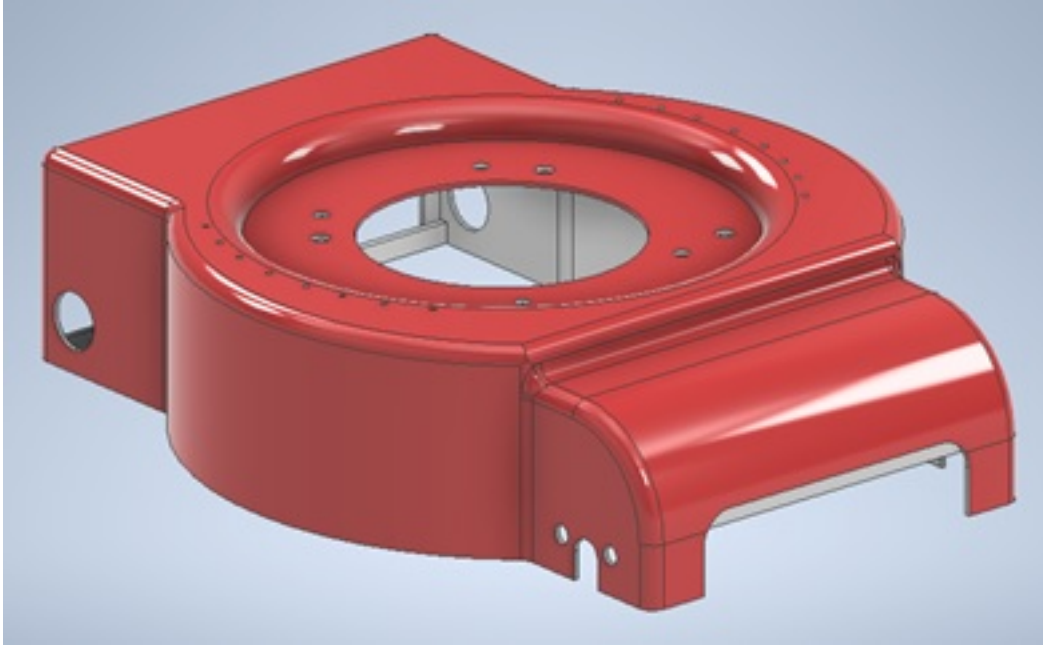
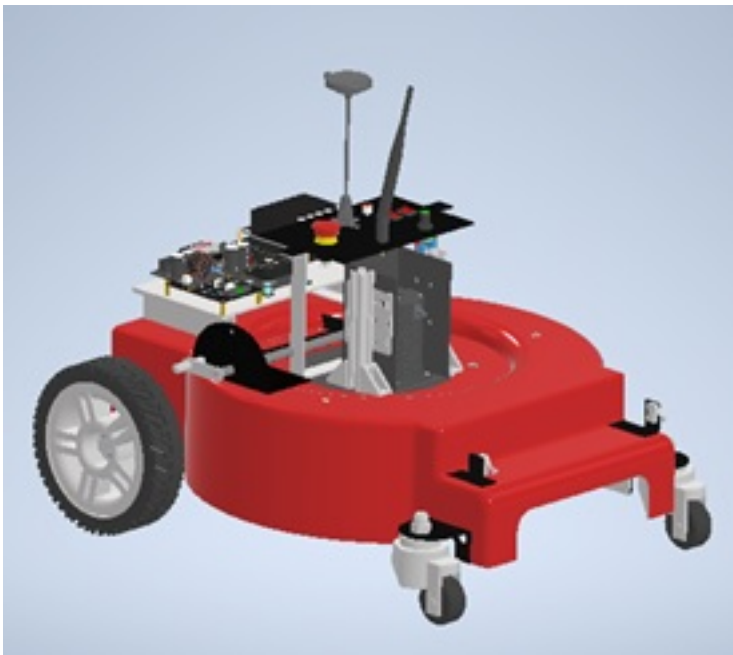

Figure 4: Lawn mower chassis

The upper part of the body houses the control system which includes a driver motor, Ardupilot, GPS antenna, and ON-OFF button. Meanwhile, the bottom part of the body is designed to accommodate the battery and motor.



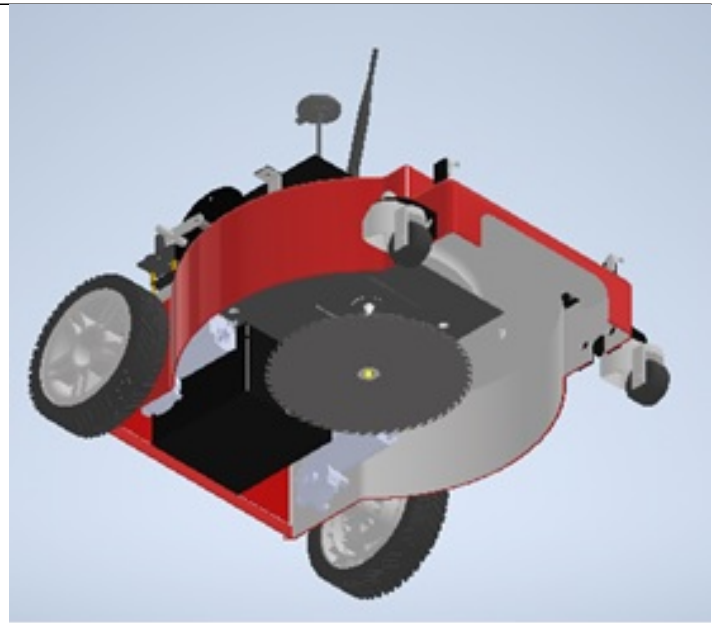

Figure 5: (a) Control system room, (b) battery and motor room

c. Battery

Two units of 12 V batteries power the entire movement and cutting of the lawn mower; one for the tyre movement and the other for the cutting and control system. A fully charged battery can provide approximately 45 min of non-stop operation. To indicate the current battery usage level, an andon light system is used with three basic colours: green (full, 24 V), yellow (half, 20 V), and red (low, 15 V). This indicator enables users to identify when the battery needs to be recharged.

d. Control System

The autonomous lawn mower uses an Ardupilot as its controller to manage its motion and operation. It is propelled by two motors, each connected to the back-left and back-right wheels. Varying the speed and direction of the wheels can cause the mower to turn left or right. For instance, to make a right turn, the speed of the left wheel will decrease to 25% in the forward direction, while the speed of the right wheel will decrease to 5% in the reverse direction. A 24 V DC motor drives the lawn mower blade, and its speed can be adjusted by using the speed knob and switched on using the RC transmitter.

Users can choose between Manual or Auto operation modes. In Manual mode, they can control the robot using the RC transmitter, while in Auto mode, they need to plot the movement using the Machine Planner software.

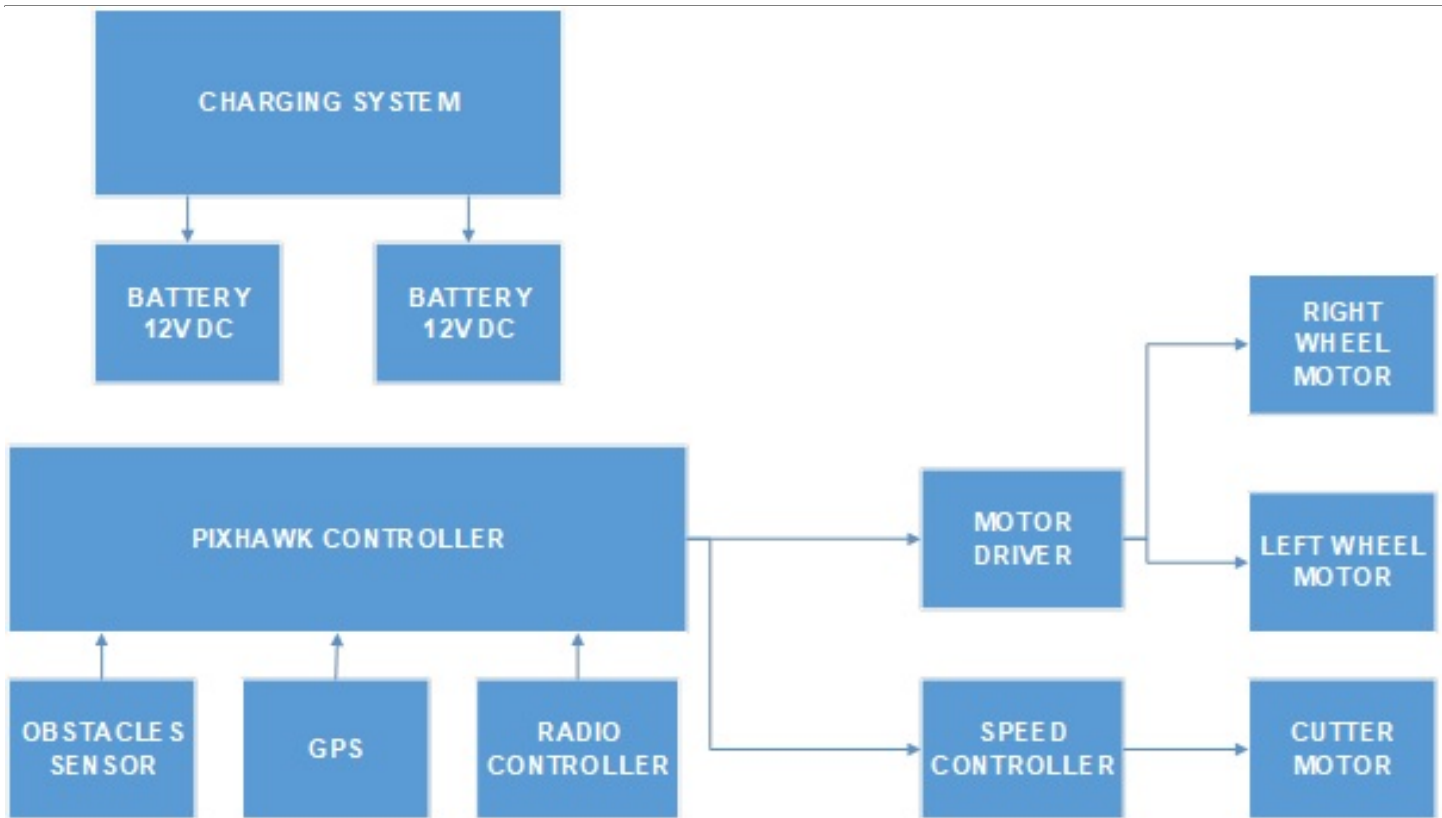

Figure 6: Control system circuit

e. Wheel System

This autonomous lawn mower is equipped with a 13-inch wheel at the back and a swivel castor wheel at the front. The rear wheel is powered by a motor and motor driver, with two motors mounted on each wheel. The motor driver used is a 90RPM GW7015 DC 24V 8Nm 4A low speed high torque worm gear reducer 2 channel MDDS30 smart drive motor driver.

f. Safety

To ensure safety during mowing, a dry contact sensor is installed at the front of the lawn mower. The sensor is installed at the front because the movement and turning of the lawn mower during mowing are exposed to the front side. When the sensor comes into contact with an obstacle, the lawn mower will stop functioning automatically.

The overall aim of the designed machine is to enhance the efficiency of lawn mowing tasks compared to existing machines. The autonomous lawn mower offers several benefits, including ease of use, cost savings, improved organisation, and reduced risk of accidents. The machine is specifically designed for flat surfaces such as football fields, and it ensures an even cutting height with its adjustable blade that can be set to three main heights.

By: Kapten Ts. Hazami Che Hussin, Ts. Mohd Adib Mohd Amin, Ts. Syahrulnaim Mohamad Nawi, Ir. Ts. Nik Mohd Zaitul Akmal Mustapha and Dr. Saifudin Razali

The writers are from the Centre for Design & Innovation of Technology (PRInT) and Faculty of Electrical and Electronics Engineering Technology, Universiti Malaysia Pahang (UMP).







[View PDF](#)